

Curved Rail  
Indoor Stairlift **Elite** -Curve

**home**<sup>®</sup>  
**ADAPT**



**QUALITY STAIRLIFTS**



*The Elite Curve is unique with a superior weight capacity of 190 kilos. The solid steel rail comfortably brings the rider up the stairs.*

### ● **Safety**

*A dual braking system makes the Elite Curve one of the safest stairlifts on the market. The electromagnetic braking system is complemented by a self locking gear box, which completely ensures your safety as you travel up and down your stairs.*

*Should anything get in the way of the stairlift as you are operating it, there are safety sensors on the foot plate and the carriage that will immediately stop the lift.*

### ● **Comfort**

*The Elite Curve has the most luxurious and comfortable seat you will ever find on a stairlift.*

### ● **Convenient Installation**

*The Elite Curve is delivered fully equipped and ready for installation.*

*The unit anchors to the steps, not the wall, and the stairlift rail can be placed as close as 178 mm from the wall.*

*When the chair's seat, footrest and armrests are folded, there is plenty of room for family and guests to use the staircase unimpeded.*



# Curved Rail Indoor Stairlift **Elite** -Curve

**Rated user weight capacity: 190 kg (30 stone)**

- **Adjustable**

*This stairlift has the biggest adjustable difference between seat and footrest height of any stairlift. There are 4 settings for the seat as well as 4 settings for the footrest.*

*The space between the armrests is adjustable and can be extended by 110 mm.*

*A large seat option is available.*

- **Quiet and smooth**

*The soft start/stop feature combined with the rack and pinion drive provide a smooth ride which is exceptionally quiet. The covered gear rack gives you a clean and attractive rail.*

- **Swivel seat**

*The offset swivel seat makes the entry and exit position at the top landing safer and easier.*

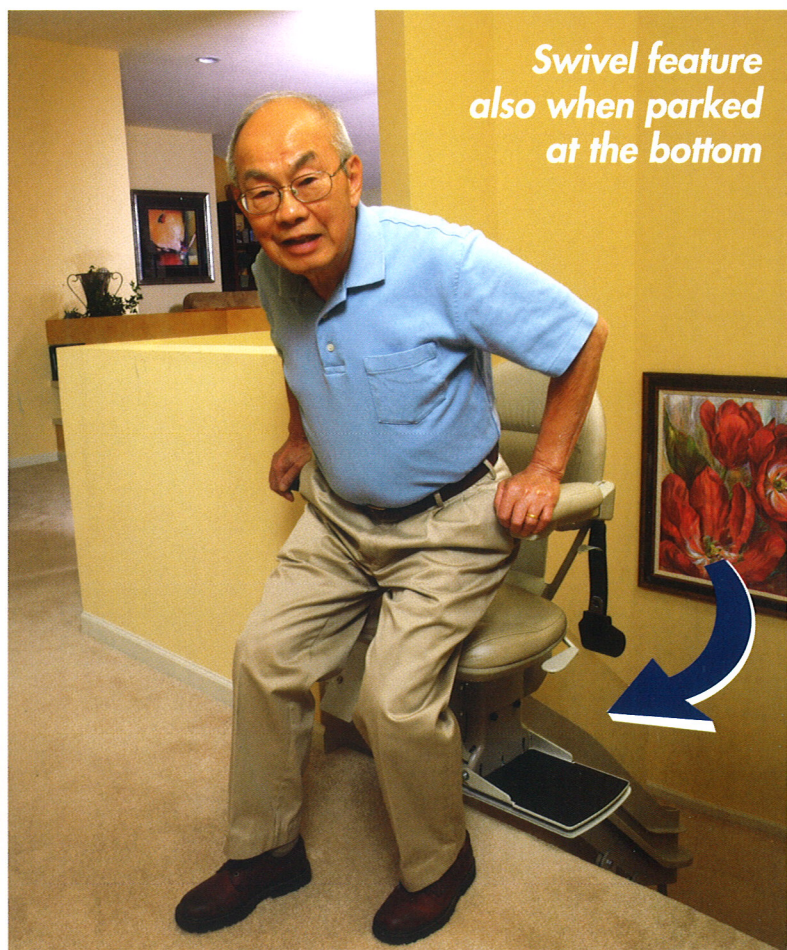



***You don't have to be limited by stairs anymore,  
so enjoy the home you love, upstairs and down!***





## ● *Battery powered*

The lift uses two 12-volt batteries that are charged from the household power supply when the lift is parked at the top or bottom of the rail or at a mid park position, if ordered as an option. The Elite Curve features strip charge contacts for more flexibility when parking. You have access to your upstairs and downstairs, even if electrical service in your home is interrupted.



The two wireless call/send controls make installation simple and clean with no wires running along the wall.

## *Rail option*

The Elite Curve can be equipped with an optional top or bottom park position to facilitate an exit and remove the unit from the stairs.

## *Obstruction sensor*

The footplate and carriage safety sensors stop the lift if the slightest obstacle is in the way.



## *Clean and elegant design*

The simple, unique design of the rail hides all mechanical components, and the installation requires no modification to your staircase.



## ● **Exceptional value**

- + Rated user weight capacity: 190 kg (30 stone).
- + Manual swivel seat at the top and bottom landing. Powered swivel at top landing only.
- + Adjustable seat height and footrest height for easier exit/entry.
- + Two remote wireless call/send controls.
- + Generous seat size between the adjustable armrests (450 - 560 mm).
- + Elegant and yet robust design and construction.
- + Retractable seat belt.
- + Footplate and carriage safety sensors.
- + On-board audio and visual diagnostics make service easier and more precise.
- + Charging-station indicator lights at the top and bottom end plates.
- + Easy-to-use rocker switch.
- + Seat pad size: 445 mm wide and 381 mm deep. (An extra large seat is available as option)

## **Options**

- ▶ Powered Swivel, operated by the rocker switch or remote control.
- ▶ Automatic powered fold-up feature for footrest. Folds and unfolds simultaneously with the seat.
- ▶ Top- and/or bottom park position around the corner.
- ▶ Rocker switch or key switch, can be mounted on either armrest.
- ▶ Extra Large Seat.  
Seat pad: 546 mm wide, 406 mm deep.  
Width between armrests: 584 mm.  
(Cannot be combined with powered swivel)
- ▶ Mid park and charge station.

## **Convenient installation**

- ▶ Installation 178 - 203 mm from wall to outside of rail.

## **Smooth, powerful drive system**

- ▶ Self-locking worm gear: rack-and-pinion drive.
- ▶ Maximum rider weight of 190 kg (30 stone).
- ▶ Soft-start, soft-stop for the user's maximum comfort.

## **Battery-powered technology**

- ▶ Ensures access even during power cuts.
- ▶ Powered by two 12-volt batteries, charged from the household power supply when the lift is parked at the top or bottom of the rail or at a mid park position, if fitted.



● **Application details** *Dimensions are based on 190 mm rail to wall position.*

**SIDE VIEWS:**

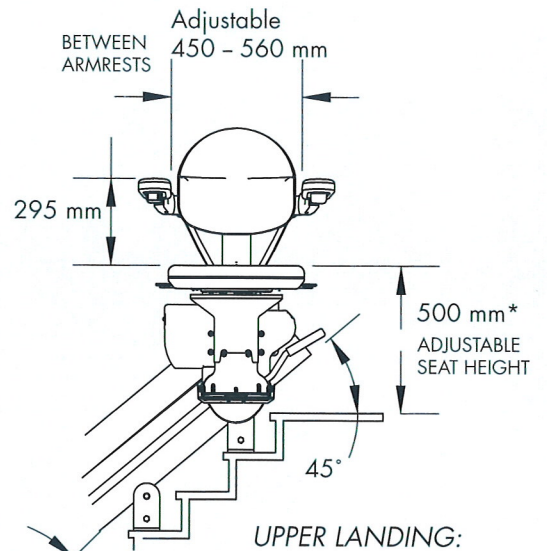
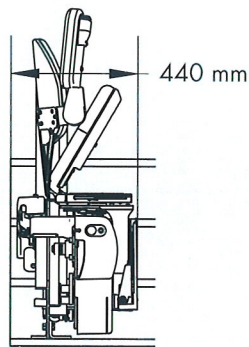
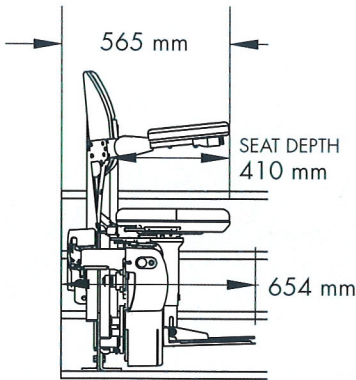

**TOP VIEW:**

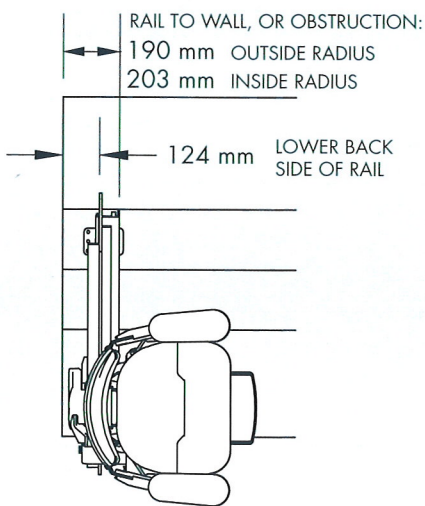

**LOWER LANDING:**

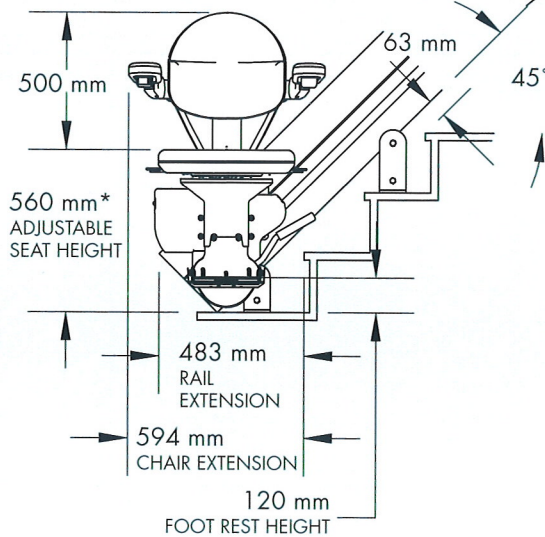

**UPPER LANDING:**

\*) Dimensions with\* are approximate and depending on the slope, riser height and custom seat adjustments made for the user.

Please note that the addition of a powered swivel seat option increases the floor-to-seat measurement by 50 mm.

**OUTSIDE RADIUS:**

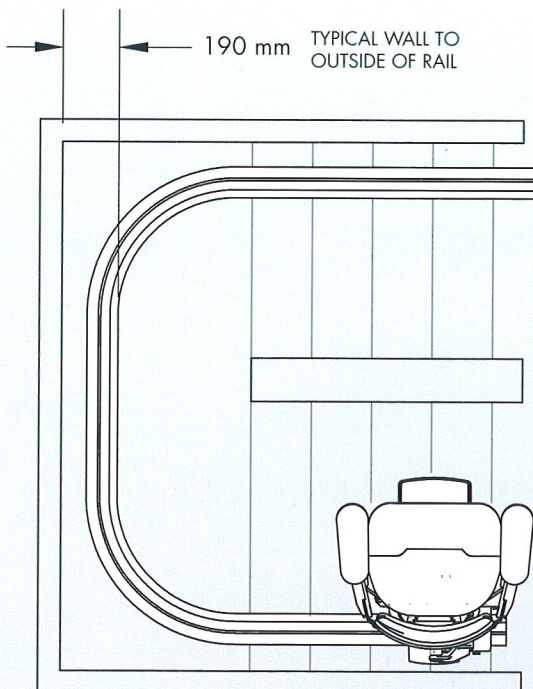

**INSIDE RADIUS:**

