

Straight Rail  
Stairlift **Elite**

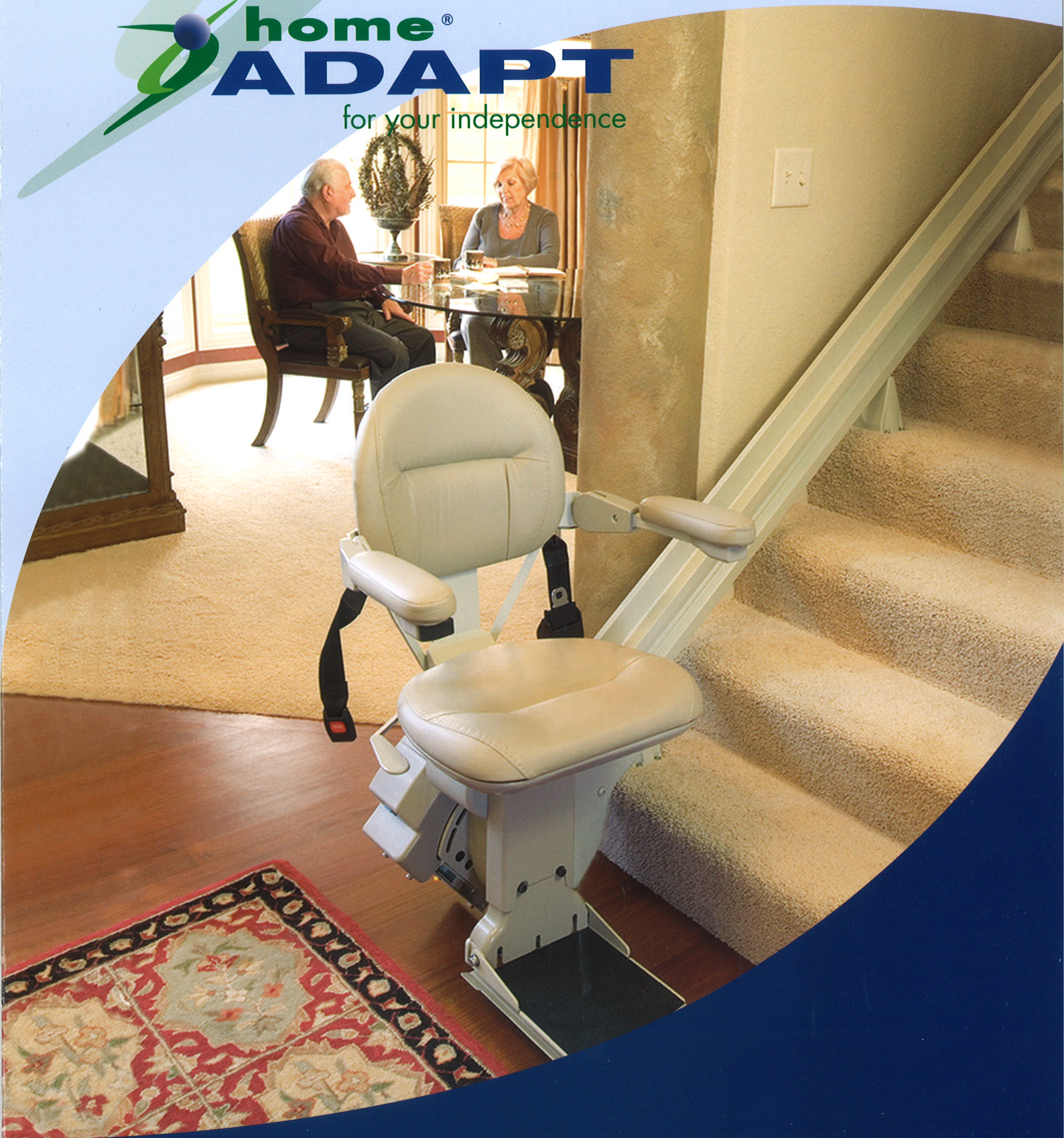

**home**<sup>®</sup>  
**ADAPT**  
for your independence



**QUALITY STAIRLIFTS**

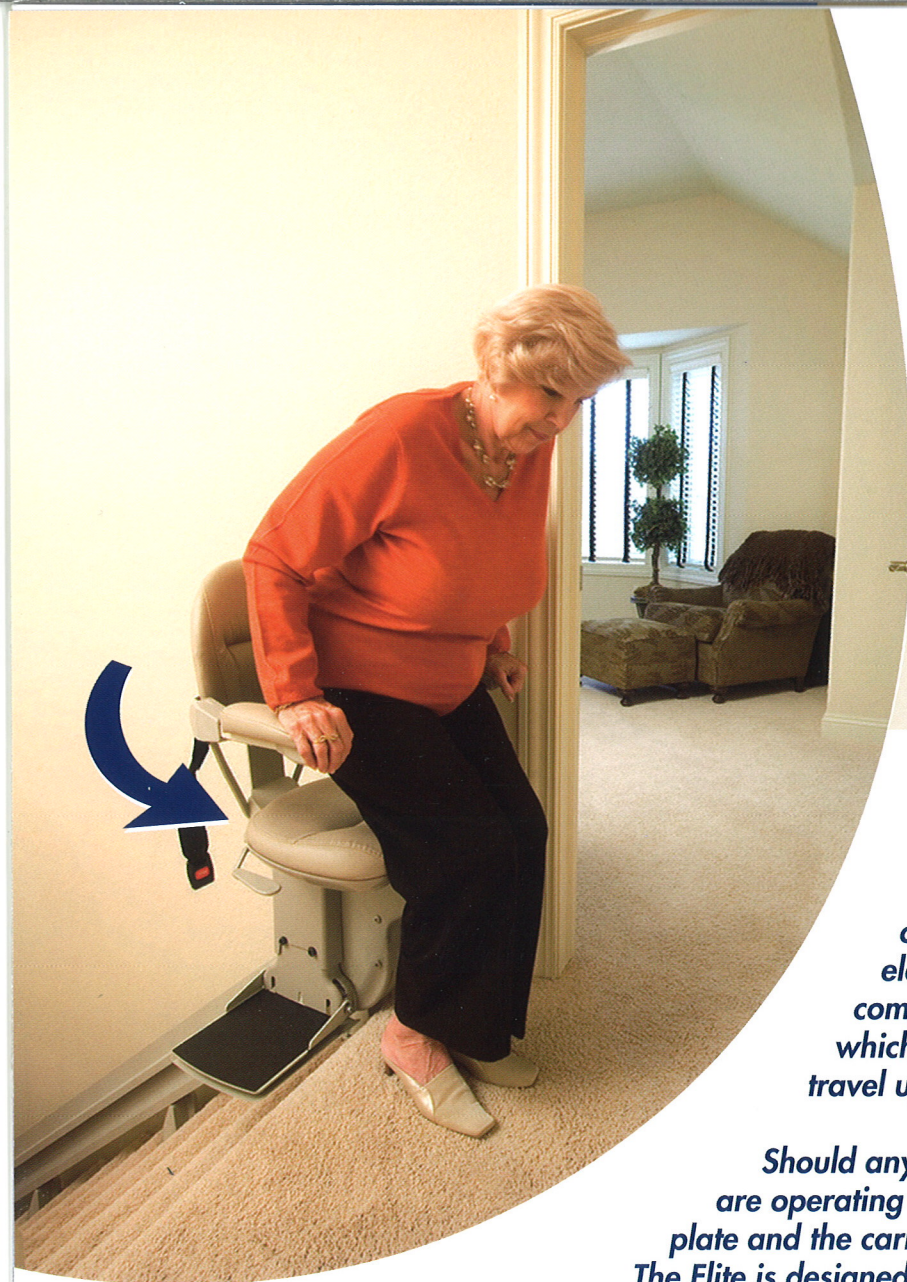

## ● **Comfort**

*The Elite has the most luxurious and comfortable seat you will ever find on a stairlift.*

## ● **Safety**

*A dual braking system makes the Elite one of the safest stairlifts on the market. The electromagnetic braking system is complemented by a self locking gear box which completely ensures your safety, as you travel up and down your stairs.*

*Should anything get in the way of the stairlift as you are operating it, there are safety sensors on the foot plate and the carriage that will immediately stop the lift. The Elite is designed to meet BS5776.*

## ● **Quiet and smooth operation**

*The soft start/stop feature combined with the rack and pinion drive provide a smooth ride which is exceptionally quiet. The covered gear rack gives you a clean and attractive rail.*



## ● **Compact**

*The slim line, upright rail is installed close to the wall.*

*The seat, armrests and footrest all fold up for a tight park position.*

# Straight Rail Stairlift **Elite**

**Rated user weight capacity: 28.5 stone**

- **Adjustable**

*This stairlift has the biggest adjustable difference between seat and footrest height of any stairlift. There are 4 settings for the seat as well as 4 settings for the footrest.*

*The space between the armrests is adjustable and can be extended by 100 mm.*

- **Swivel seat**

*The seat swivels at the top landing for easy entry/exit. At time of installation, the seat can also be set to swivel at the bottom of the stairs, which is useful in narrow hallways.*



*You don't have to be limited by stairs anymore, so enjoy the home you love, upstairs and down!*

**home<sup>®</sup>**  
**ADAPT**  
for your independence  
**QUALITY STAIRLIFTS**



## ● **Battery powered**

The lift uses two 12-volt batteries that are charged from the household power supply when the lift is parked at the top and bottom of the rail. The Elite features strip charge contacts for more flexibility when parking. You have access to your upstairs and downstairs, even if electrical service in your home is interrupted.



The two wireless call/send controls make installation simple and clean with no wires running along the wall.

## **Obstruction sensor**

The footplate and carriage safety sensors stop the lift if the slightest obstacle is in the way.



## **Clean and simple rail**

The simple, unique design of the rail hides all mechanical components. The rail is powder coated in a neutral colour, giving it a finished appearance.



## **Comfort**

Contoured seat for maximum comfort. The seatbelt is retractable as not to be in the way.



## ● Application details

# Straight Rail **Elite** Stairlift

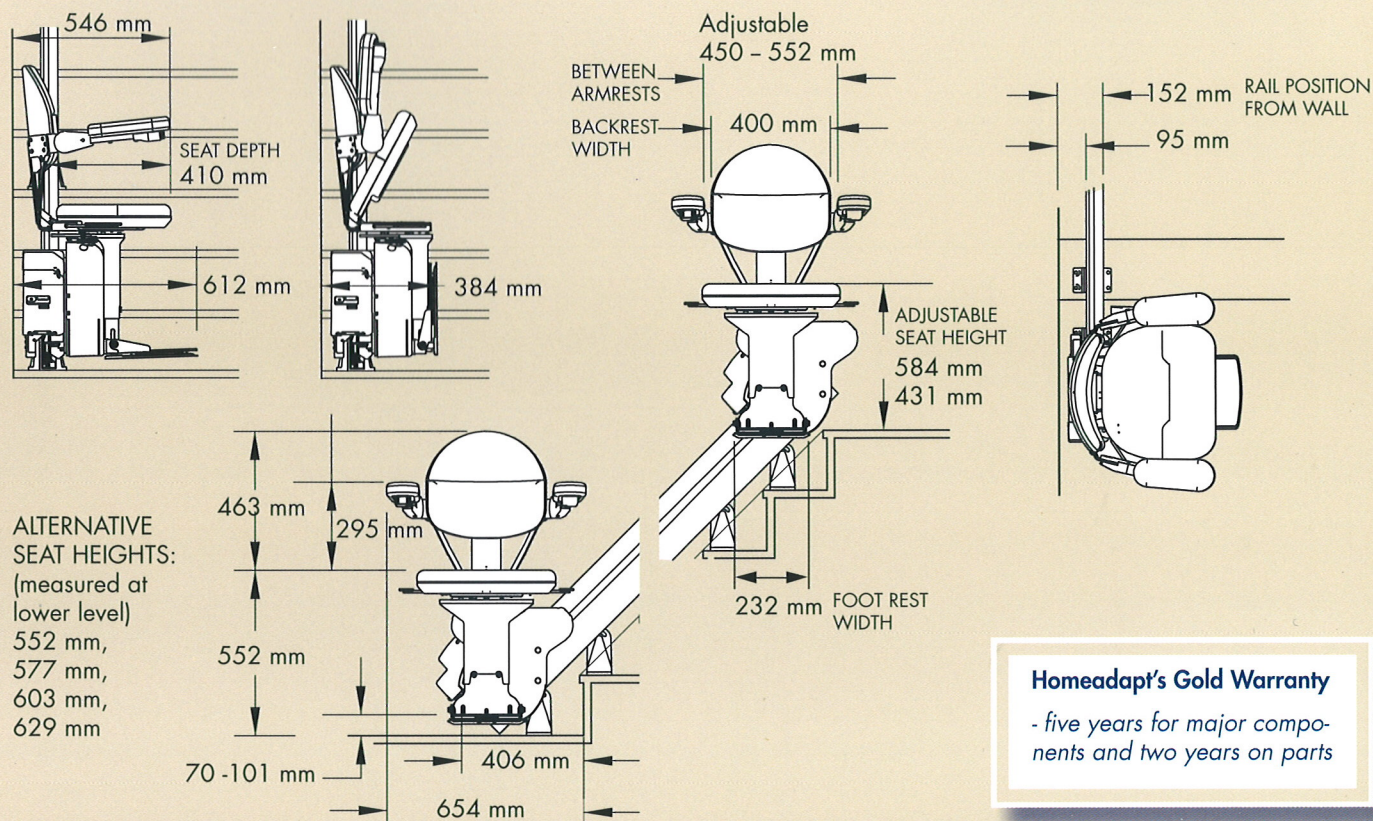

### Homeadapt's Gold Warranty

- five years for major components and two years on parts

## ● Exceptional value

- ▶ A rated user weight capacity of 28.5 stone (181 kg)
- ▶ Offset locking swivel seat at the top and bottom landing.
- ▶ Designed to meet BS5776.
- ▶ Adjustable seat height and footrest height for easier exit/entry.
- ▶ Two remote wireless call/send controls.
- ▶ Generous seat size between the armrests (450 - 550 mm)
- ▶ Elegant and yet robust design and construction.
- ▶ Retractable seat belt
- ▶ Footplate and carriage safety sensors.
- ▶ On-board audio and visual diagnostics make service easier and more precise.
- ▶ Charging-station indicator lights at the top and bottom end plates.
- ▶ Easy-to-use rocker switch.
- ▶ Seat pad size: 445 mm wide and 381 mm deep. (An extra large seat is available as option)

## Convenient installation

- ▶ Rail installs to within 152 mm of the wall.
- ▶ Standard track lengths - each rail comes in two sections; 2 x 2.45 m = 4.9 m and 2 x 3 m = 6 m.

## Smooth, powerful drive system

- ▶ Self-locking worm gear: rack-and-pinion drive.
- ▶ Maximum rider weight of 28.5 stone (181kg).
- ▶ Soft-start, soft-stop for the user's maximum comfort.

## Battery-powered technology

- ▶ Ensures access even during power cuts.
- ▶ Powered by two 12-volt batteries, charged from the household power supply when the lift is parked at the top and bottom of the rail.

## Options

- ▶ Powered Swivel, operated by the rocker switch or remote control.
- ▶ Automatic powered fold-up feature for footrest. Folds and unfolds simultaneously with the seat.
- ▶ Manual Hinge
- ▶ Rocker switch and key switch, can be mounted on either armrest.
- ▶ Large Seat. Seat pad: 546 mm wide, 406 mm deep. Width between armrests: 584 mm.